

DESCRIPTION

La barre verticale FPK020 offre de multiples possibilités d'exercices d'étirements et permet la réalisation d'exercices de musculation.



BÉNÉFICES

- Etirements
- Musculation
- Mobilité
- Flexibilité



SCHEMAS TECHNIQUES

(Mesures en mm)

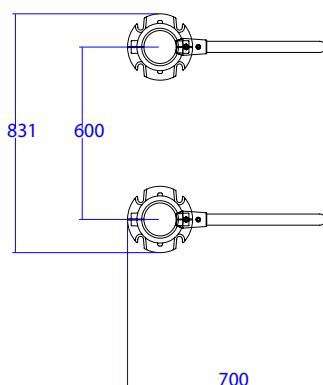
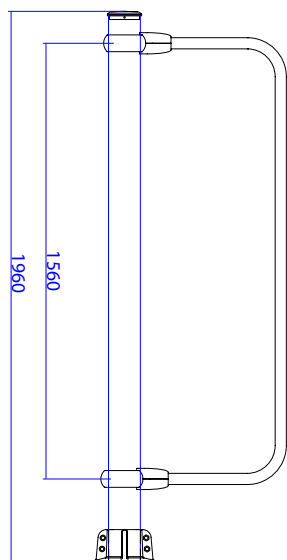
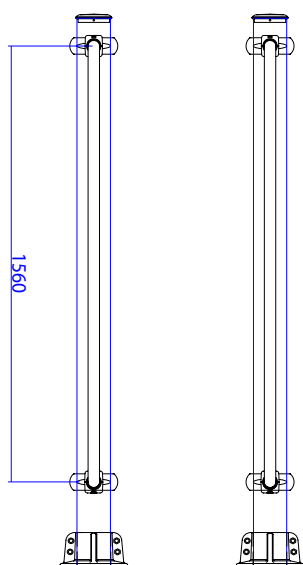

PLAN D'OCCUPATION DES SOLS

