



### DESCRIPTION

La barre verticale FPK019 offre de multiples possibilités d'exercices d'étirements et permet la réalisation d'exercices de musculation.

### BÉNÉFICES

- Etirements
- Musculation
- Mobilité
- Flexibilité



### SCHÉMAS TECHNIQUES

(Mesures en mm)

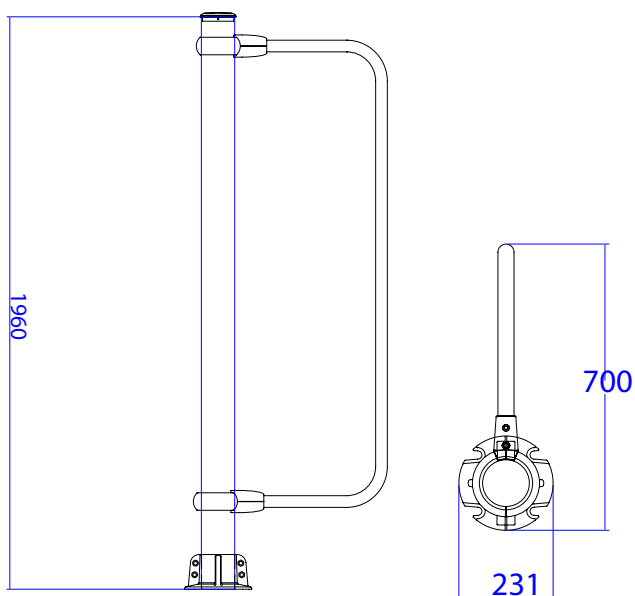

### PLAN D'OCCUPATION DES SOLS

